

SPECTRAFILL Green LED

ESL2G11

Broadband Light-emitting Diode

Spectrafill green LED is a broadband (wide emission spectrum) solid-state light emitter. Its spectral width is roughly three times wider than that of usual narrow band LEDs. The polychromatic emission from this device contains correspondingly more shades of green colour, making it suitable for high fidelity illumination applications. This LED can be used on its own or as one of a red, green, blue (RGB) full colour set. The device is available in through hole, surface mount and power packages.



Typical Applications

- Decorative and architectural RGB lighting systems
- High CRI white light luminaries
- Plant grow lights
- Broadband green lighting for machine vision applications
- Spectroscopy and microscopy

Key Features

- Broad emission in the green region
- Emitted light contains yellow and blue components as well
- Lead free and RoHS compliant
- ESD and reverse voltage protection

Principal Parameters

Forward voltage drop: 3.0 V
 Peak emission wavelength: 507 nm
 Wavelength spread (FWHM): 104 nm
 Emission angle: 120 °
 Typical CIE chromaticity coordinates: 0.34 (x), 0.50 (y)
 Typical luminous intensity (low power LED): 8000 mcd
 Typical luminous intensity (high power LED): 75 Lumens
 Typical operating current (low power LED): 20 mA
 Typical operating current (high power LED): 250 mA
 Operating temperature range: -40 °C to 80 °C
 Lifetime: 50,000 hours
 Lens geometry: Round

Absolute Maximum Ratings

Maximum continuous operating Current (low power LED): 30 mA
 Maximum continuous operating Current (high power LED): 300 mA
 Maximum power dissipation (low power LED): 120 mW
 Maximum power dissipation (high power LED): 1W
 Maximum reverse voltage: 5 V
 Maximum soldering temperature: 260 °C for 5 sec

Packaging: ESL2G11 is available in T-1 3/4 5 mm diameter through hole transparent epoxy package plastic leaded chip carrier (PLCC) surface mount device (SMD) 3528 package and 1W power package.

Electrical and Optical Characteristics

Current-voltage characteristics

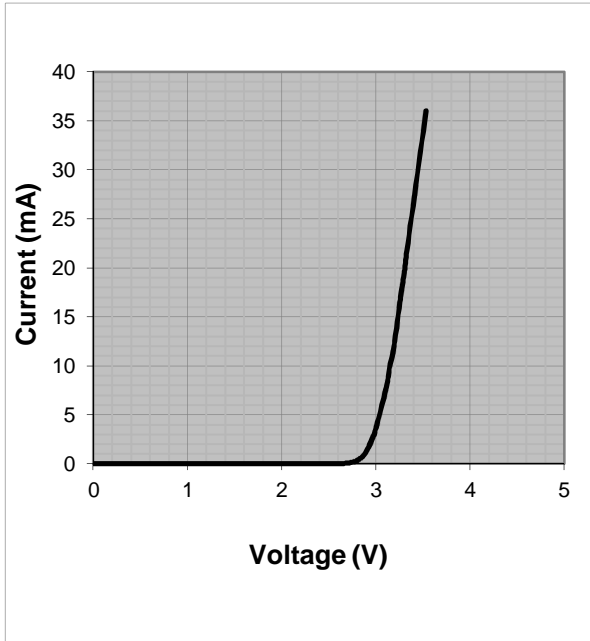

Light intensity versus LED drive current

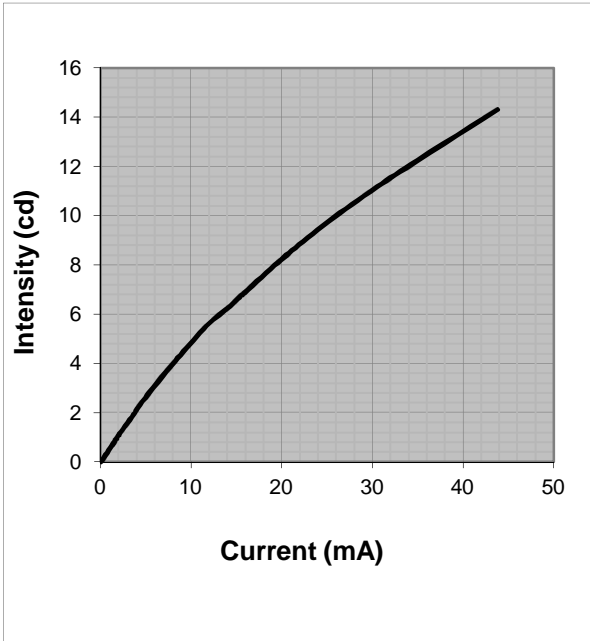

Optical spectrum

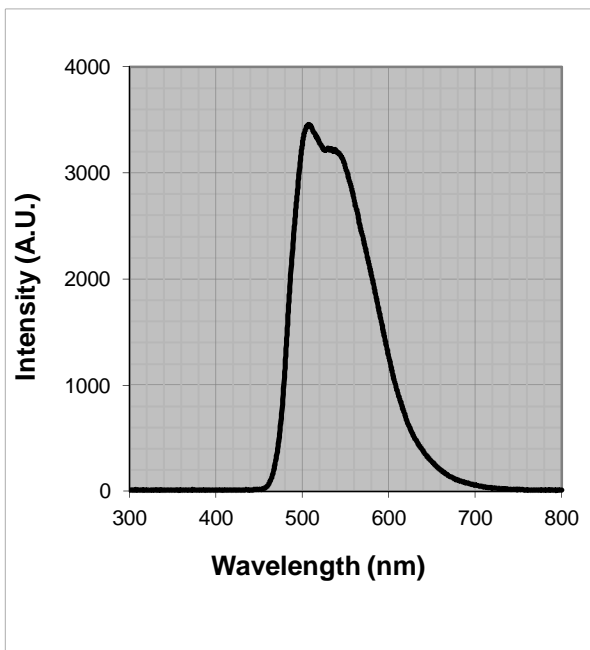

Angular light emission pattern

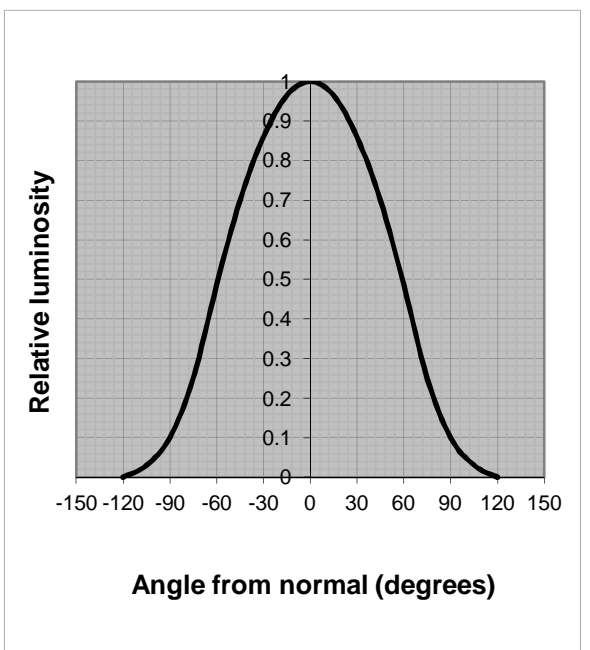

Application Information

General

Spectrafill LEDs can be operated in both continuous and pulsed modes. The latter may be more power-efficient in certain applications. Like other LEDs, these devices start emitting light once their forward voltage drop exceeds their emission threshold. Thereafter, the light continues to increase in intensity as the drive current increases. The output optical power begins to saturate at high drive currents due to carrier saturation and thermal effects. This saturation is reached at lower currents when the device is operated at higher ambient temperatures. Adequate heat sinking must be provided to ensure satisfactory performance in terms of optical output, lumens maintenance and device lifetime. See more about this in the Design Considerations section below.

Analogue Drive

Spectrafill LEDs can be driven by a continuous current drive. A stable, high internal impedance current source is recommended for this purpose. There are both fixed and variable current sources commercially available that are suitable for this purpose. Fixed current sources, such as the NSI45030AT1G from ON Semiconductor provide a set current through an LED whereas the current output from a variable source, such as the PSSI2021SAY from NXP or the LM134 from Linear Technology can be adjusted using a trimming resistor. The current drive from all these and other similar devices is stable enough to drive Spectrafill LEDs at constant brightness and colour point.

Digital Drive

For more precise control and reproducible colour generation, Spectrafill LEDs can be driven by a digital pulse width modulation (PWM) signal. Generally, 8 bit precision is sufficient for most applications but if needed 10 or 16 bit systems can also be implemented.

This approach requires the use of either a microcontroller or a dedicated PWM generator. Most general-purpose microcontrollers are suitable for this application although some manufacturers also offer devices optimised for lighting control. Please note that digital drive requires a MOSFET power driver external to the microcontroller in order to handle the drive current requirements of Spectrafill LEDs. ElectrosPELL can provide details of a reference design based on Atmel AVR 8-bit microcontrollers.

Design Considerations

Good electrical, thermal and optical designs are the keys to obtaining good performance from LEDs. Please make sure that stable, noise-free power is provided to these LEDs for best performance and long operating life. This can be done by placing a voltage regulator before the constant current source that drives LEDs. Also make sure that printed circuit board (PCB) tracks are wide and thick enough to handle current fed to LEDs. These devices should be mounted with proper heat sinking if they are to be driven at high power levels. Placing the LED package body on a metal core PCB (MC-PCB) or in contact with a metal heat sink is recommended. Filling the space between the LED and the heat sink with a suitable thermal interface material, such as Thermadime, is also recommended. Please note that significant increase of LED temperature can lead to reduced performance and premature failure. Spectrafill LEDs emit light in a circularly symmetric Lambertian pattern with most light emitted normal to the device and the intensity falling at larger angles from the normal according to a cosine distribution function. In order to collect the maximum amount of light, proper reflectors should be used. These could be a feature of the product housing or can be inserted as accessory components. Proper choice and placement of reflector can maximise the amount of light that can be obtained from a lighting system.

Circuit Examples

A simple resistor-connected circuit such as the one shown below can be used to drive Spectrafill LEDs. For most applications, a current between 20 and 30 mA will drive the LED at sufficient brightness. Power LED can be driven similarly at higher current levels, using a resistor with a suitable power rating.

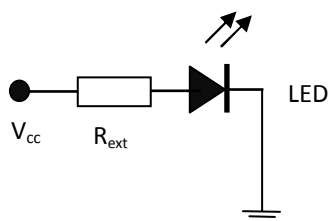

For better performance, where the supply voltage can change, use of constant current sources is recommended. The PSSI202SAY constant current IC can be used for this purpose for currents up to 50 mA, as shown below. Please refer to the PSSI202SAY datasheet for further information. For higher currents, use a transistor-based constant current source.

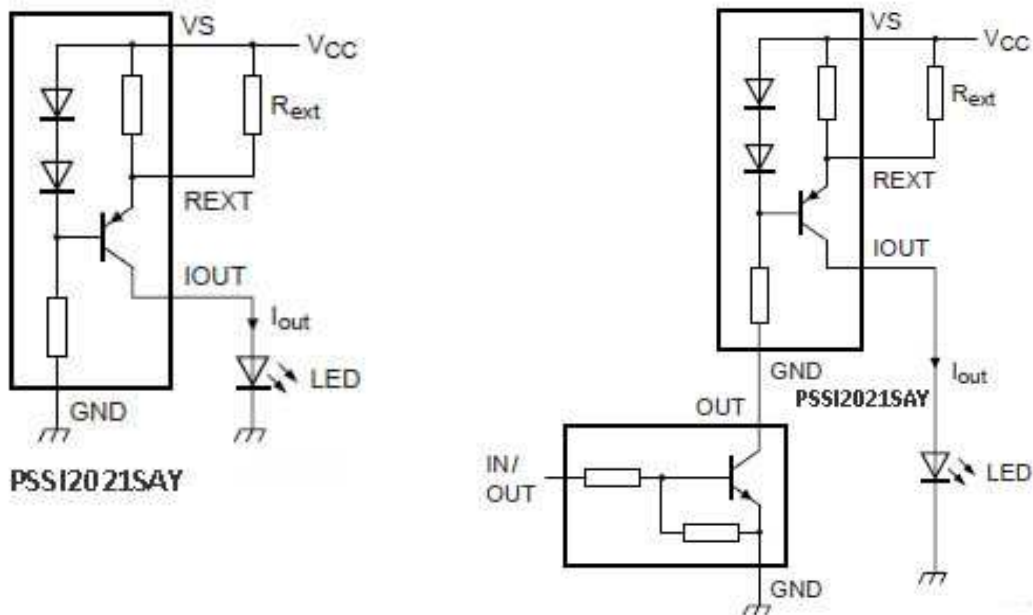

For digital PWM drive at low current levels, low power Spectrafill LEDs can be directly connected to microcontroller I/O pins with a suitable series resistor. For driving power Spectrafill LEDs, a power interface circuit using a MOSFET such as IRFZ34 and a MOSFET driver such as LT1910 are needed. Please contact ElectrosPELL for further information about LED drive electronics.

SMD PLCC (3528) Package Drawing - All dimensions are in mm

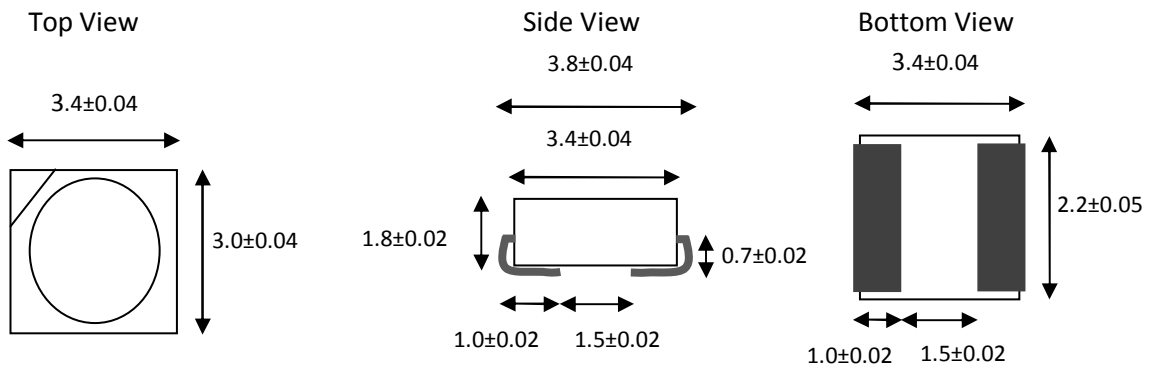

Emitting Aperture Diameter: 2.4 mm

Through-hole (T1-3/4) Package Drawing - All dimensions are in mm

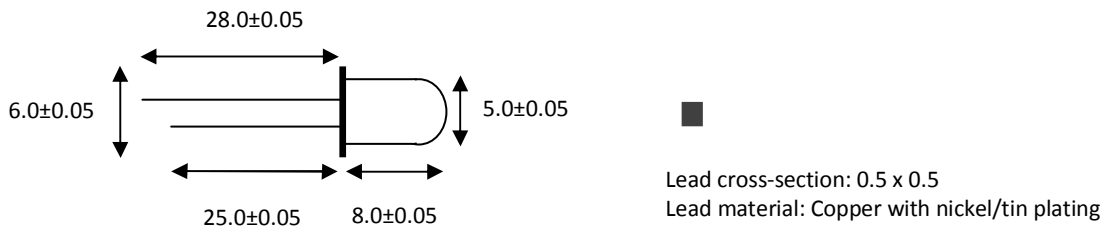

1W Power Package Drawing - All dimensions are in mm

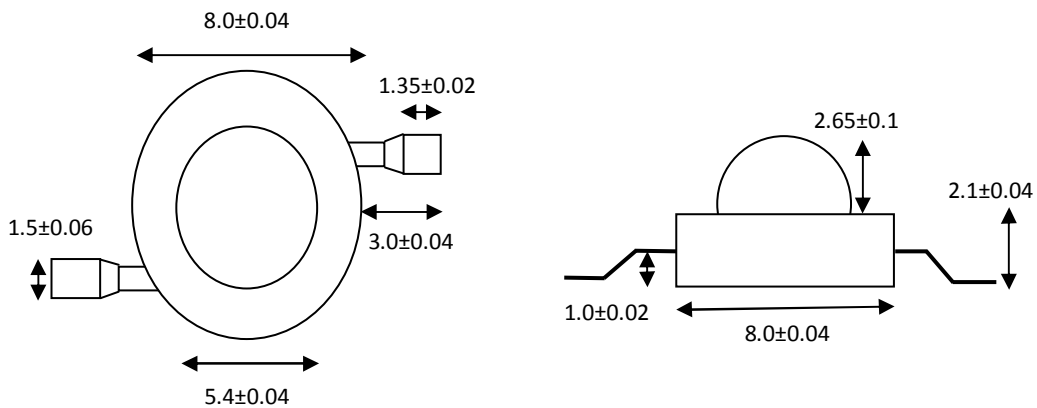

Note: Drawings are not to scale - to obtain values in inches, multiply by 0.04

Recommended land pattern and through-hole solder pattern

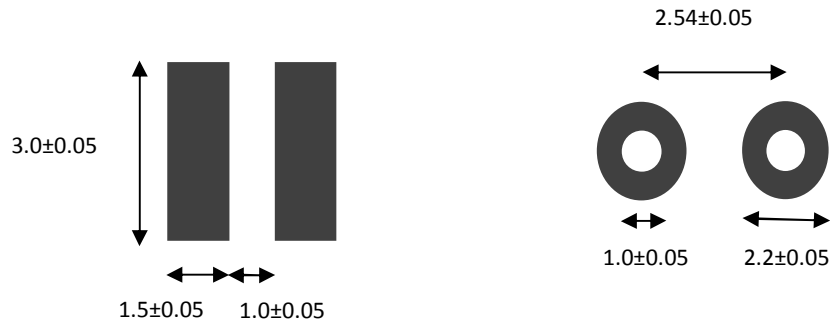

Recommended land pattern for 1W power package

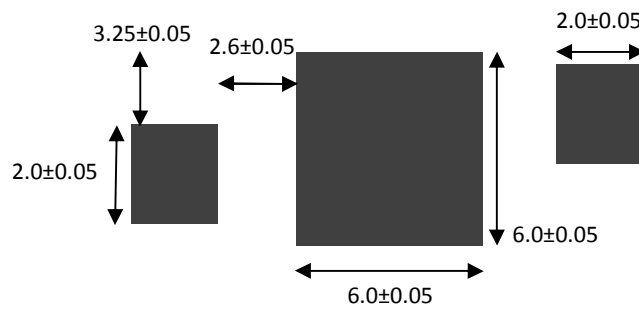

Note: Drawings are not to scale - to obtain values in inches, multiply by 0.04

Product availability and ordering information

Spectrafill Green LEDs are available in the following two packaging styles:

Through hole T-1 ¾ (5 mm diameter) epoxy package
Product code: ESL2G11-TH01

[Longer lead identifies the anode (+) terminal]



Surface Mount Device PLCC plastic package
Product code: ESL2G11-SMD01

[Corner depression identifies the cathode (-) terminal]
This product is also available in 1000 piece reels.



Surface Mount Power LED package
Product code: ESL2G11-P01

[Circular notch on solder terminal identifies the
Cathode (-) terminal]

To purchase any of the above products please contact ElectrosPELL or its distributors.

ElectrosPELL Ltd
Block 7, Kelvin Campus
West of Scotland Science Park
Glasgow G20 0SP
United Kingdom
Tel: +44 (0) 141 579 3030
Fax: +44 (0) 141 579 3033

PRP Inc
4200 E La Palma Boulevard
Anaheim
CA 92807
United States of America
Tel: (714) 528-5001
E-mail: sales@electrosPELL.com