

Tungsten LED

EWL4T12

Tungsten Bulb Simulation Light-emitting Diode

Tungsten LED is a yellow-white solid-state light emitter. Its spectrum is similar to that of ISO tungsten lamps. The warm white light emission from this device closely resembles that from traditional incandescent bulbs, making it suitable for general purpose illumination applications. This LED is suitable for making luminaires that appear the same as conventional tungsten filament lamps. The device is available in surface mount low-power and power LED packagings.



Typical Applications

- Retrofit light bulbs and general luminaires
- High CRI warm white luminaries
- Studio lighting for still and cine photography

Key Features

- Warm white light emission with distinct yellow emphasis
- Spectrum similar to that of ISO tungsten lamp
- Lead free and RoHS compliant
- ESD and reverse voltage protection

Principal Parameters

Forward voltage drop (at 200 mA): 3.0 V
 Peak emission wavelength: 640 nm
 Wavelength spread (5%): 287 nm
 Emission angle: 120 °
 Typical CIE chromaticity coordinates: 0.40 (x), 0.35 (y)
 Typical luminous intensity: 60 Lumens
 Typical operating current: 200 mA
 Operating temperature range: -40 °C to 120 °C
 Lifetime: 50,000 hours
 Lens geometry: Round

Absolute Maximum Ratings

Maximum continuous operating current: 300 mA
 Maximum pulsed operating current (20% duty cycle): 500 mA
 Maximum power dissipation: 1 W
 Maximum reverse voltage: 5 V
 Maximum soldering temperature: 260 °C for 5 sec

Packaging: EWL4T12 is available in low power and power LED surface mount device (SMD) 3528 packages.

Electrical and Optical Characteristics

Current-voltage characteristics

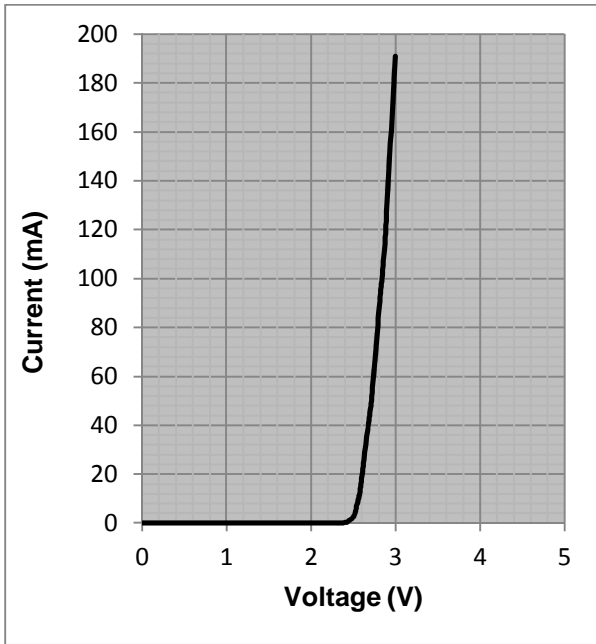

Light intensity versus LED drive current

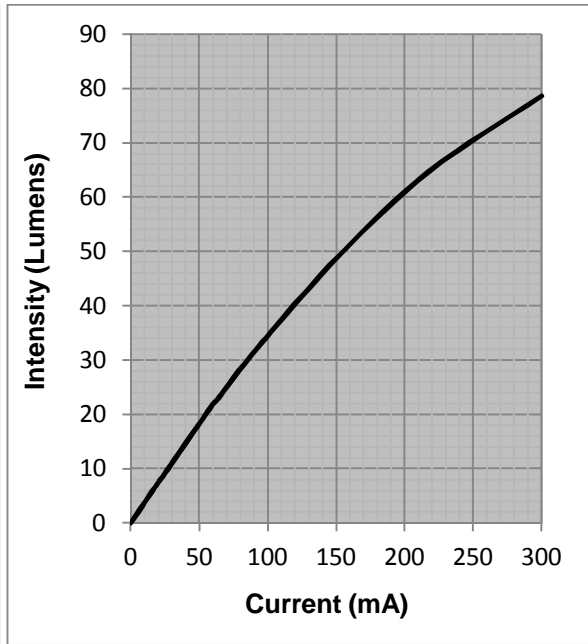

Optical spectrum

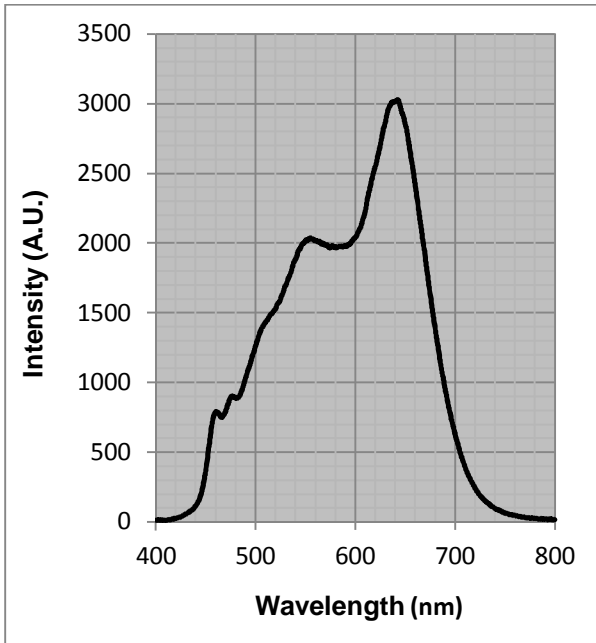

Angular light emission pattern

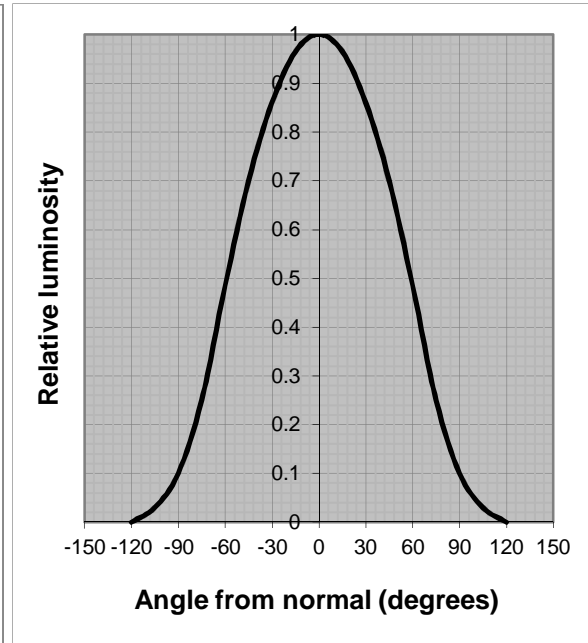

Application Information

General

Electrospell Tungsten LEDs can be operated in both continuous and pulsed modes. The latter may be more power-efficient in certain applications. Like other LEDs, these devices start emitting light once their forward voltage drop exceeds their emission threshold. Thereafter, the light continues to increase in intensity as the drive current increases. The output optical power begins to saturate at high drive currents due to carrier saturation and thermal effects. This saturation is reached at lower currents when the device is operated at higher ambient temperatures. Adequate heat sinking must be provided to ensure satisfactory performance in terms of optical output, lumens maintenance and device lifetime. See more about this in the Design Considerations section below.

Analogue Drive

Tungsten LEDs can be driven by a continuous current drive. A stable, high internal impedance current source is recommended for this purpose. There are both fixed and variable current sources commercially available that are suitable for this purpose. Fixed current sources, such as the NSI45030AT1G from ON Semiconductor provide a set current through an LED whereas the current output from a variable source, such as the PSSI2021SAY from NXP or the LM134 from Linear Technology can be adjusted using a trimming resistor. The current drive from all these and other similar devices is stable enough to drive Tungsten LEDs at constant brightness.

Digital Drive

For more precise control, Tungsten LEDs can be driven by a digital pulse width modulation (PWM) signal. Generally, 8 bit precision is sufficient for most applications but if needed 10 or 16 bit systems can also be implemented.

This approach requires the use of either a microcontroller or a dedicated PWM generator. Most general-purpose microcontrollers are suitable for this application although some manufacturers also offer devices optimised for lighting control. Please note that digital drive requires a MOSFET power driver external to the microcontroller in order to handle the drive current requirements of Tungsten LEDs. Electrospell can provide details of a reference design based on Atmel AVR 8-bit microcontrollers.

Design Considerations

Good electrical, thermal and optical designs are the keys to obtaining good performance from LEDs. Please make sure that stable, noise-free power is provided to these LEDs for best performance and long operating life. This can be done by placing a voltage regulator before the constant current source that drives LEDs. Also make sure that printed circuit board (PCB) tracks are wide and thick enough to handle current fed to LEDs. These devices should be mounted with proper heat sinking if they are to be driven at high power levels. Placing the LED package body on a metal core PCB (MC-PCB) or in contact with a metal heat sink is recommended. Filling the space between the LED and the heat sink with a suitable thermal interface material, such as Thermadime, is also recommended. Please note that significant increase of LED temperature can lead to reduced performance and premature failure. Tungsten LEDs emit light in a circularly symmetric Lambertian pattern with most light emitted normal to the device and the intensity falling at larger angles from the normal according to a cosine distribution function. In order to collect the maximum amount of light, proper reflectors should be used. These could be a feature of the product housing or can be inserted as accessory components. Proper choice and placement of reflector can maximise the amount of light that can be obtained from a lighting system.

Circuit Examples

A simple resistor-connected circuit such as the one shown below can be used to drive Tungsten LEDs. Use a resistor with a suitable power rating.

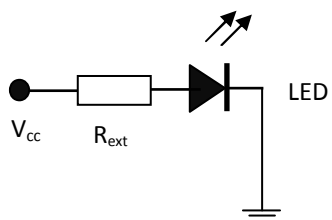

For better performance, where the supply voltage can change, use of constant current sources is recommended. The PSSI202SAY constant current IC can be used for this purpose for currents up to 50 mA, as shown below. Please refer to the PSSI202SAY datasheet for further information. For higher currents, use a transistor-based constant current source.

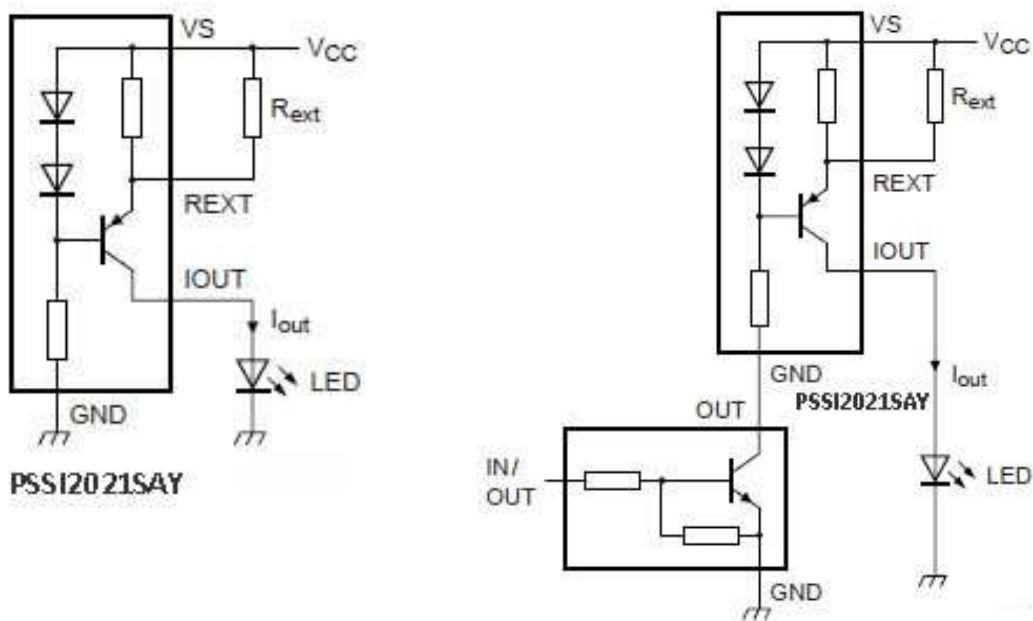

For digital PWM drive, a power interface circuit using a MOSFET such as IRFZ34 and a MOSFET driver such as LT1910 are needed. Please contact ElectrosPELL for further information about LED drive electronics.

SMD PLCC (3528) Package Drawing - All dimensions are in mm

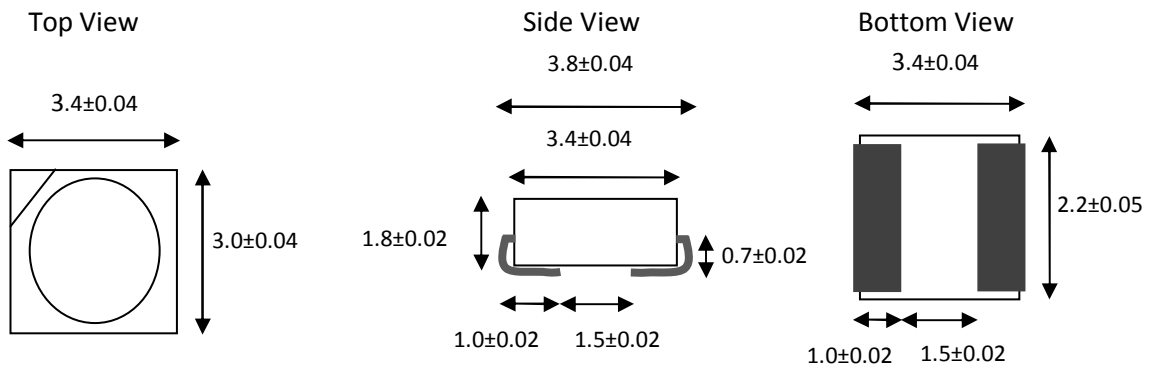

Emitting Aperture Diameter: 2.4 mm

1W Power Package Drawing - All dimensions are in mm

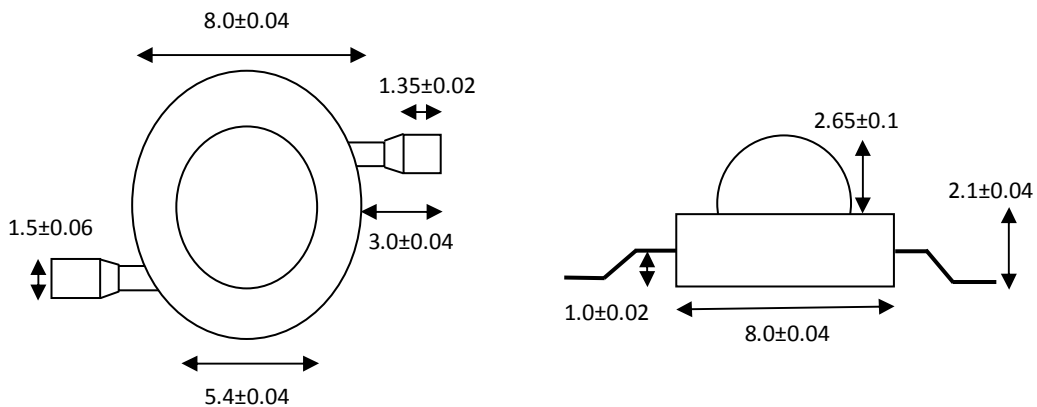

Recommended land patterns for SMD and power packages

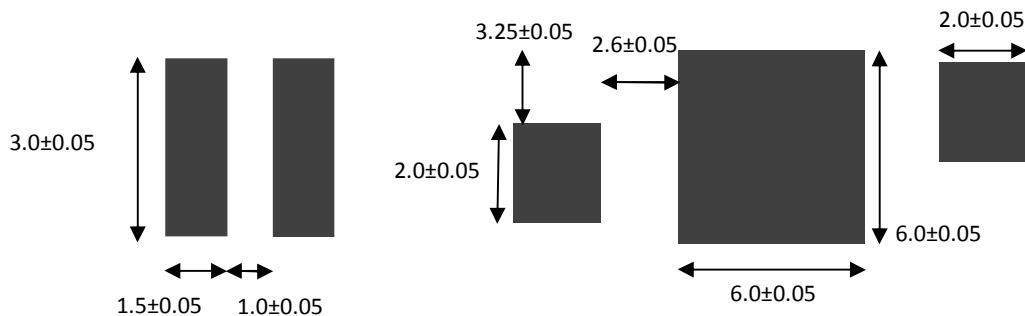

Note: Drawings are not to scale - to obtain values in inches, multiply by 0.04

Product availability and ordering information

Tungsten LEDs are available in the following packaging style:

Surface Mount Device PLCC plastic package
Product code: EWL4T12-SMD01

[Corner depression identifies the cathode (-) terminal]
This product is also available in 1000 piece reels.



Surface Mount Power LED package
Product code: EWL4T12-P01

[Circular notch on solder terminal identifies the
Cathode (-) terminal]



To purchase Tungsten LEDs please contact ElectrosPELL or its distributors.

ElectrosPELL Ltd
Block 7, Kelvin Campus
West of Scotland Science Park
Glasgow G20 0SP
United Kingdom
Tel: +44 (0) 141 579 3030
Fax: +44 (0) 141 579 3033

PRP Inc
4200 E La Palma Boulevard
Anaheim
CA 92807
United States of America
Tel: (714) 528-5001
E-mail: sales@electrosPELL.com